

Netflix

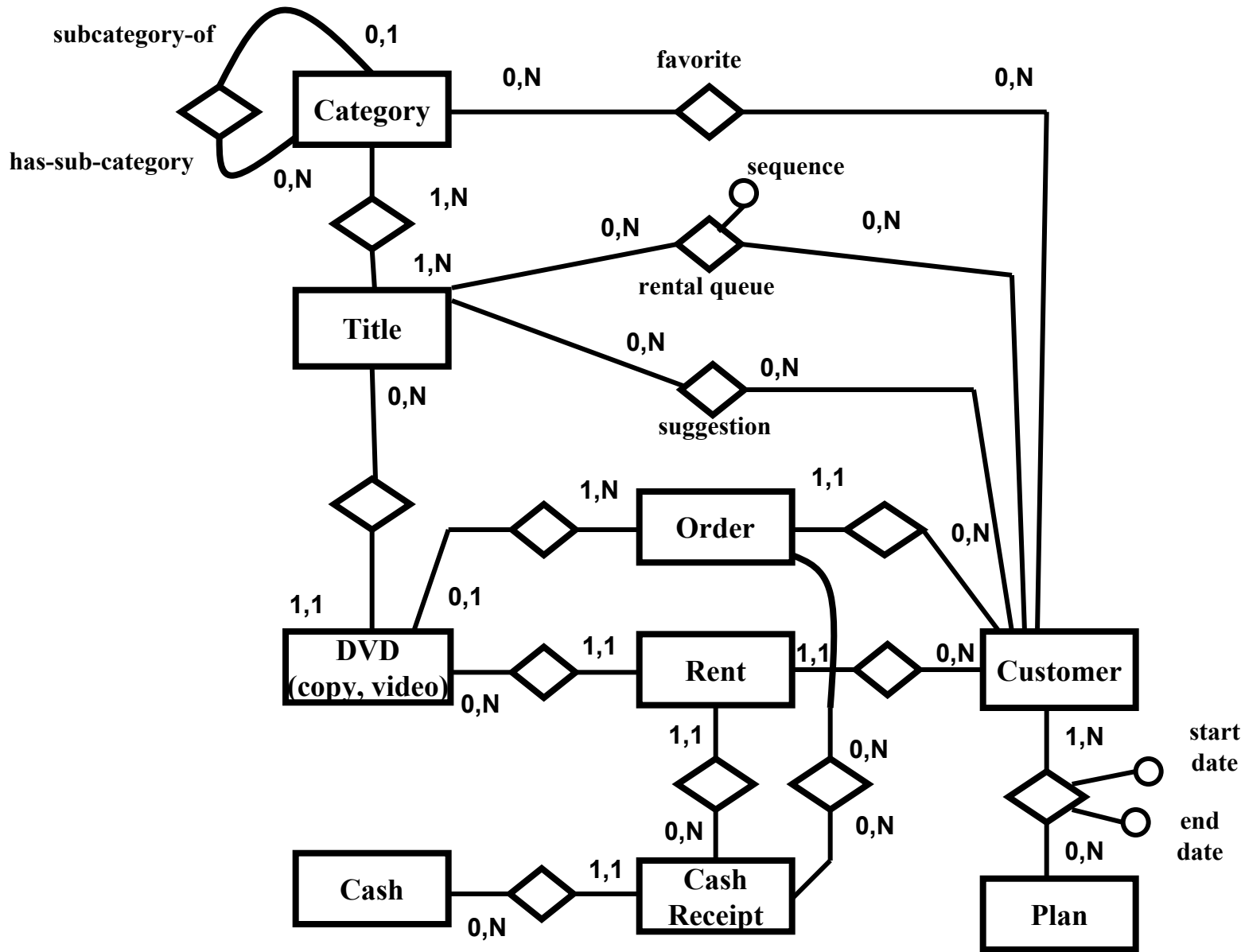

Solution Package



**Integrated
Solution**

A

“For example, we offer the title “Karakter” (a foreign film) for more than two years but it has not been requested yet. We don’t have a copy of it “

B

“We often buy a large number of videos of a new release ... “ and we thus have (own) multiple copies of the same title.

C

“We record exactly one title for each DVD.”

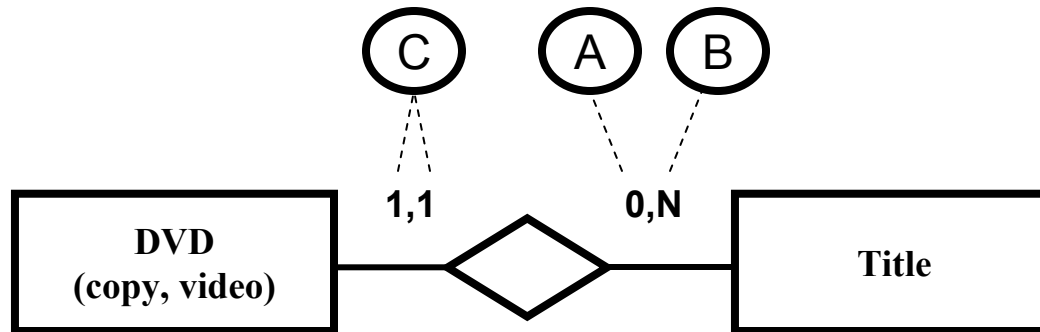

A

“We record at least one category for each title.”

B

“Only categories (including subcategories) are recorded for which we offer at least one title.”

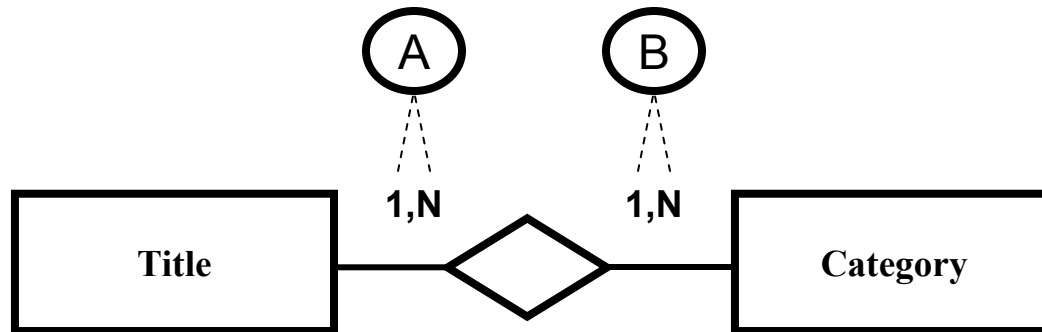

(A)

“A category often has subcategories. For example, for history we have modern and roman history subcategories, and for biography we have entertainment, politics, etc.”

(B)

“Not all categories have sub-categories.”

(C)

“... at most one (parent) category for each (child) subcategory (i.e., we have a hierarchical classification system).”

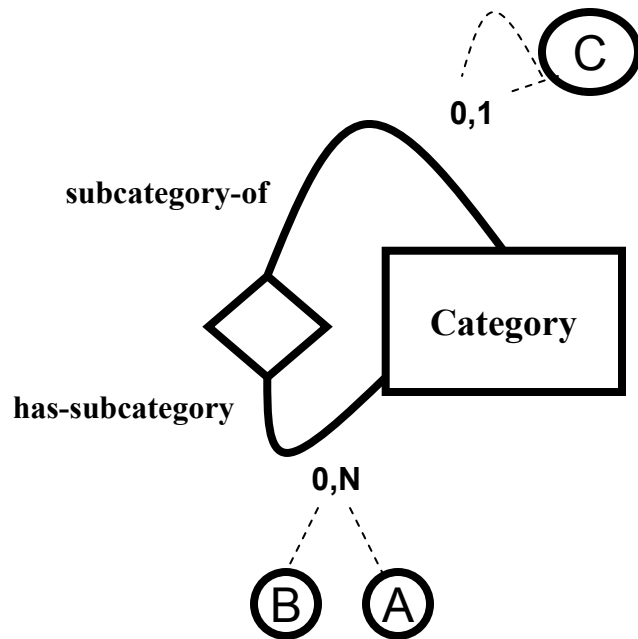

This category has more than one subcategory.

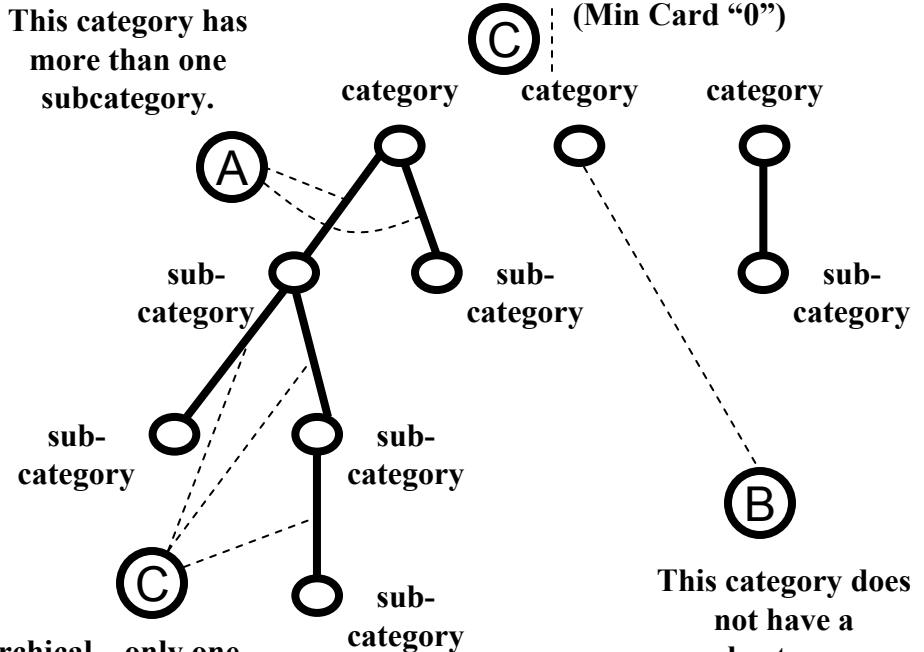

“This instance does not participate as a subcategory in the recursive relationship” (Min Card “0”)

“Hierarchical – only one category can be defined for a subcategory” (Max Card “1”)

This category does not have a subcategory.

A

“Customers change plans over time.
We track a customer’s history; i.e. we keep track of all the different plans the customer participated in.”

B

“G is our most popular plan with more than 250,000 customers.”

C

“We record plan information when the customer enrolls for the first time.”

D

“Last year we tried the “Junkie” plan where customers where able to sign up for 10 DVDs at a time for \$49.99 a month. No customer ever signed up !”

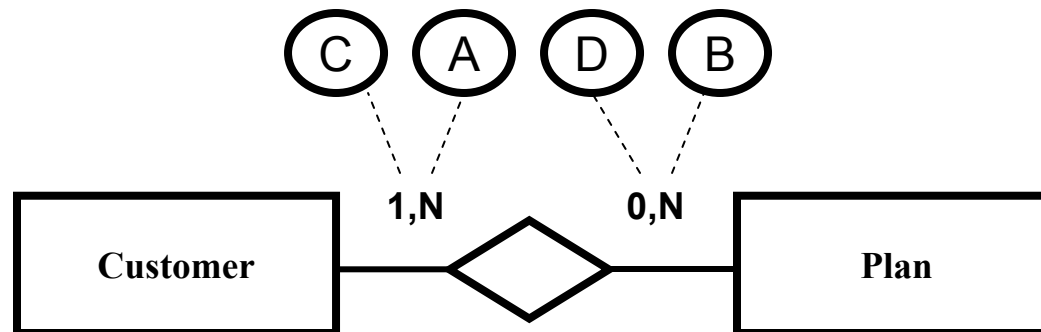

- (A) “Customers can select any number of categories as their favorite categories. “
- (B) “Most customers select two or three categories, some select more, some select none. “
- (C) “Comedy is currently the most popular category (more than a 300,000 customers).“
- (D) “Nobody has selected ‘political documentaries’ as their favorite category yet.”

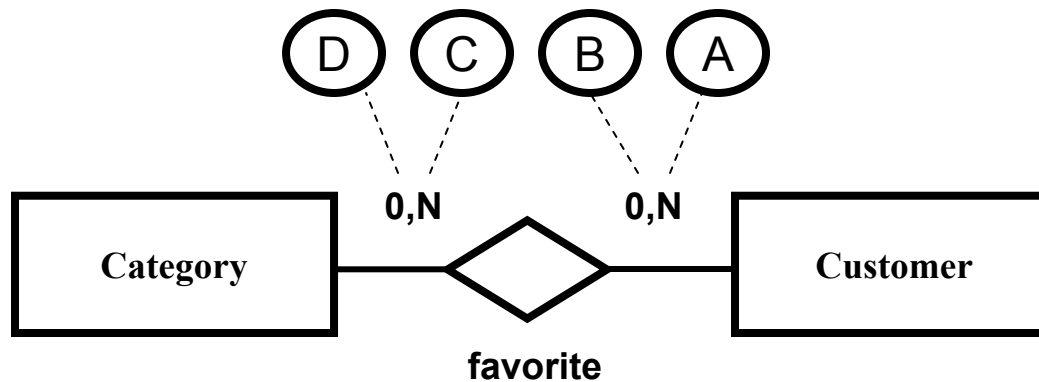

- (A) “Customers can put an unlimited number of titles in their queue.”
- (B) “A title is removed from the customer’s queue once it is shipped (to the customer). Customers are sent an e-mail when their queue is empty ... “
- (C) “More than 100,000 customers had “Dreamgirls” (title) in their rental queue last week.”
- (D) “ ... we offer the title “Karakter” (a foreign film) for more than two years but it has not been requested yet.”
- (E) “ ... we also generate (and record) a list of (individualized) suggestions for each customer Our goal is to have at least 3 suggestions in each customer’s ‘suggestion list.’ “
- (F) “ ... record our first suggestions one week after a customer enrolls.”
- (G) “We have thousands of movies that we have never used as a suggestion. “
- (H) “We currently have “Grease” (title) as a suggestion for more than 100,000 customers.”

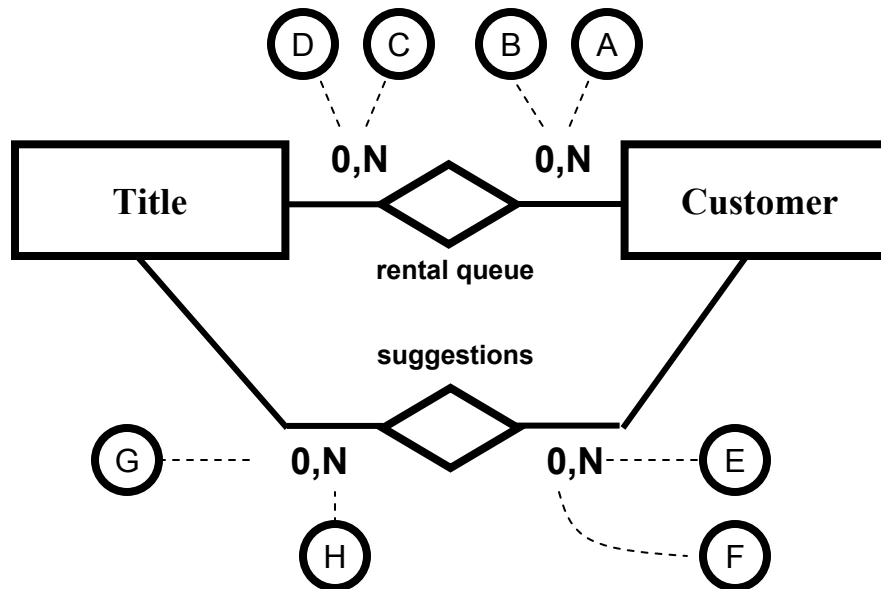

A

“We record exactly one customer per shipment.”

B

“ ... ship the next item “

C

“ It takes most customers at least a couple of days to create their first rental queue (after enrollment).”

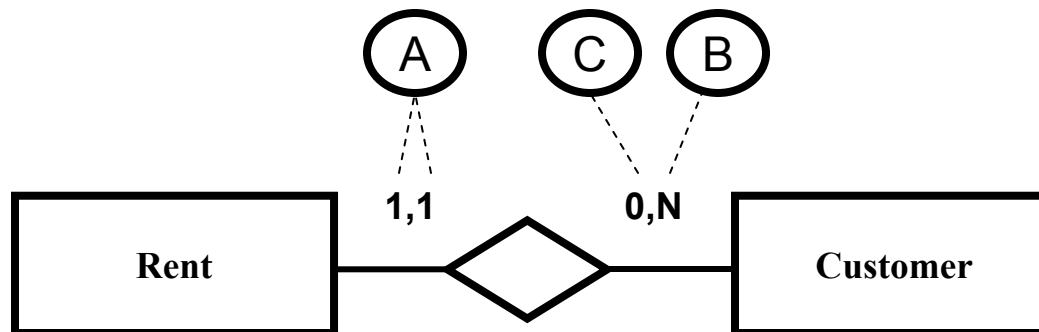

A

“There is exactly one DVD per shipment.”

B

“The same video can be rented many times.”

C

“No one has requested this title yet.”

We have copies available but we haven’t rented/shipped them yet since they were not requested yet.

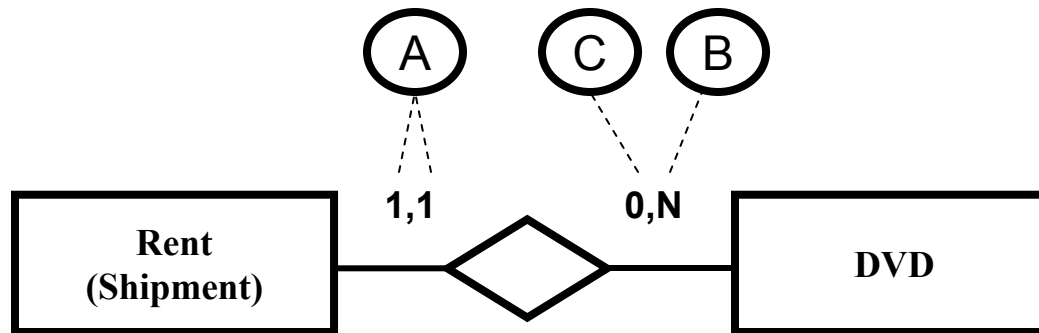

A

“We record exactly one payment for each rental (shipment).”

B

“ ... prepayment... ”

C

“ ... independent of how many movies we ship to her during a month.”

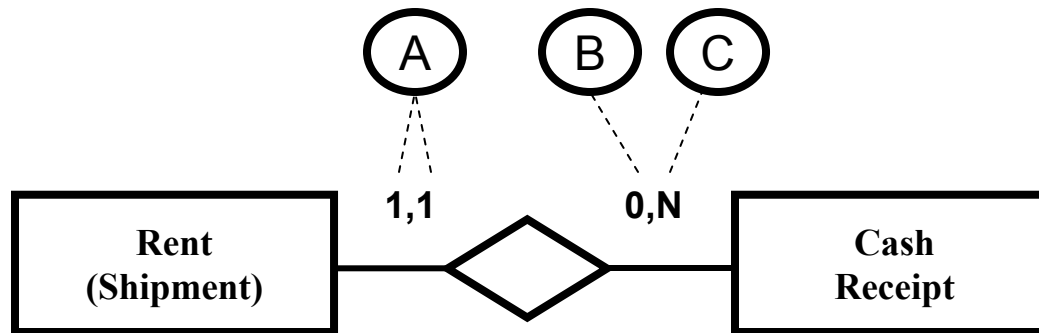

- (A) “There is at least one video per order.”
- (B) “Obviously, a video can be ordered (and sold) only once.”
- (C) “ ... we sell most of them after one year. ... “
- (D) “There is exactly one customer per (sales) order.”
- (E) “Most of our customers don’t buy (order) DVD’s; they only rent. “
- (F) “However, some customers place (sales) order more that twice a month.”

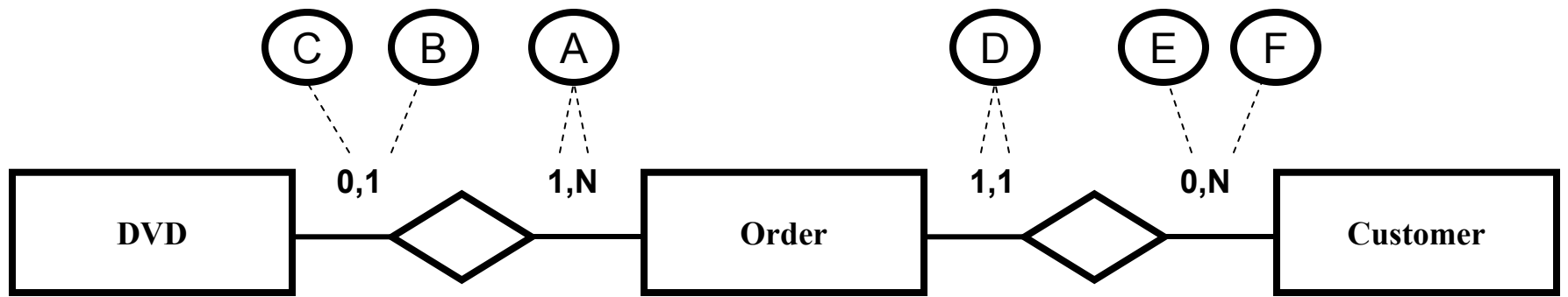

- A** “Customers are asked to pay within 30 days ... “
- B** “We accept installments.”
- C** “Often, customers pay for a number of (sales) orders with one check.”
- D** “Most of our customers don’t buy (order) DVD’s; they only rent. A few customers have only bought DVD’s; i.e., they don’t rent DVD’s.” So, some payments are for rentals only while other payments are for (sales) orders only.

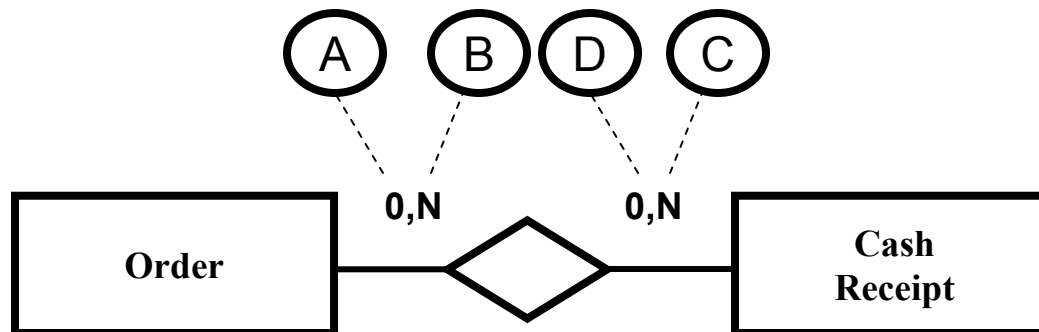

- (A) Exactly one account is recorded for each payment.
- (B) We currently have an account for which there are no cash receipts yet .
- (C) Cash is always a type.

